

märklin
H0



Dampfkran Ardelt 57t
49570

Inhaltsverzeichnis:	Seite
Informationen zum Vorbild	4
Sicherheitshinweise	8
Wichtige Hinweise	8
Funktionen	8
Ergänzende Hinweise	8
Schaltbare Funktionen	9
Betriebshinweise: Fahrbetrieb	24
Betriebshinweise: Kranbetrieb	26
Ergänzendes Zubehör	32
Parameter / Register	34
Wartung und Instandhaltung	36
Ersatzteile	38

Sommaire :	Page
Informations concernant la locomotive réelle	6
Remarques importantes sur la sécurité	12
Information importante	12
Fonctionnement	12
Indication complémentaire	12
Fonctions commutables	13
Remarques sur l'exploitation : Circulation	24
Remarques sur l'exploitation : Exploitation de la grue	26
Accessoires complémentaires	32
Paramètre / Register	34
Entretien et maintien	36
Pièces de rechange	38

Table of Contents:	Page
Information about the prototype	5
Safety Notes	10
Important Notes	10
Functions	10
Supplemental Notes	10
Controllable Functions	11
Information about operation: Running Operation	24
Information about operation: Crane Operation	26
Complementary accessories	32
Parameter / Register	34
Service and maintenance	36
Spare Parts	38

Inhoudsopgave:	Pagina
Informatie van het voorbeeld	7
Veiligheidsvoorschriften	14
Belangrijke aanwijzing	14
Functies	14
Extra opmerking	14
Schakelbare functies	15
Opmerkingen over de werking: Rijbedrijf	24
Opmerkingen over de werking: Kraanbedrijf	26
Aanvullende toebehoren	32
Parameter / Register	34
Onderhoud en handhaving	36
Onderdelen	38

Indice de contenido:	Página	Innehållsförteckning:	Sidan
Aviso de seguridad	16	Säkerhetsanvisningar	20
Notas importantes	16	Viktig information	20
Funciones	16	Funktioner	20
Indicaciones complementarias	16	Kompletterande information	20
Funciones conmutables	17	Kopplingsbara funktioner	21
Instrucciones de uso: Modo circulación	24	Driftnvisningar: Körning	24
Instrucciones de uso: Modo grúa	26	Driftnvisningar: Krandrift	26
Accesorios complementarios	32	Ytterligare tillbehör	32
Parámetro / Registro	34	Parameter / Register	34
El mantenimiento	36	Underhåll och reparation	36
Recambios	38	Reservdelar	38

Indice del contenido:	Página	Indholdsfortegnelse:	Side
Avvertenze per la sicurezza	18	Vink om sikkerhed	22
Avvertenze importanti	18	Vigtige bemærkninger	22
Funzioni	18	Funktioner	22
Avvertenze supplementari	18	Tillægsbemærkninger	22
Funzioni commutabili	19	Styrbare funktioner	23
Avvertenze per il funzionamento: Esercizio di marcia	24	Brugsanvisninger: Køredrift	24
Avvertenze per il funzionamento: Esercizio della gru	26	Brugsanvisninger: Krandrift	26
Accessori complementari	32	Ekstra tilbehør	32
Parametro / Registro	34	Parameter / Register	34
Manutenzione ed assistere	36	Service og reparation	36
Pezzi di ricambio	38	Reserve dele	38

Informationen zum Vorbild

Für einen reibungslosen Bahnbetrieb sind Instandhaltung und Ausbau des Schienennetzes unerlässlich. Zu den hierzu erforderlichen Arbeiten gehören u.a. das Auswechseln von Weichen, das Beschneiden hochgewachsener Bäume oder das Eingleisen von Lokomotiven und Waggons. Nach Unfällen müssen Lokomotiven und Wagen geborgen, Trümmer beseitigt und Rettungsmaßnahmen oft unter enormem Zeitdruck schnell und effizient in die Wege geleitet werden. Dabei sind die Rahmenbedingungen oft nur suboptimal oder einfach nur schlecht: Manchmal besitzt eine Bahnlinie keine nebenherführende Straße oder sie ist komplett isoliert wie in Tunneln, bei Steigungsabschnitten oder tiefen Einschnitten. Oft ist auch eine Vielzahl an Hindernissen wie Oberleitungen, Bahnsteige, Masten, Pfosten oder Signalanlagen zu bewältigen. Daher benötigt die Bahn speziell auf ihre Erfordernisse perfekt angepasste Kräne, welche u.a. eine entsprechende Beweglichkeit und Verfahrbarkeit mit und ohne Last im Gleis, ein effizientes Heben, Abstützen und Positionieren und eine exzellente Manövrierbarkeit selbst in schwer zugänglichen oder kniffligen Arealen gewährleisten.

Viel aufzuräumen gab es in den Westzonen nach dem Zweiten Weltkrieg und so bestellte die DRG 1948 bei der Firma Ardelt vier Dampfkranne mit Traglast von 57 Tonnen, welche 1949 geliefert und von der gerade gegründeten DB als Essen 6660, Mainz 6600, München 6664 und Wuppertal 6602 eingereiht wurden. Diese Kräne waren so konstruiert, dass ihr Gegengewicht beim Transport auf dem Unterwagen abgelegt und die unteren Teile des Gegengewichtes mittels der beiden Haspelräder im „Bauchladen“ zwischen Pufferbohle

und Stützarmscharnieren verstaut werden konnten. Damit realisierte man bei dem sechsachsigen Fahrzeug ohne Überschreitung der mittleren Radsatzlast von 18 t, einer angemessenen Ausladung und einer tragbaren Abstützbreite von sechs Metern immerhin noch eine maximale Tragkraft von 57 t. Bei einer Überführung musste lediglich der das Lichtraummaß überschreitende Schornsteinaufsatz abgenommen und hinten über den Gewichten verzurrt werden. Der Kranwagen besaß ein Gesamtgewicht von 106 t. Ein als Schutzwagen vorangestellter Rungenwagen mit Lagerbock verhinderte ein Ausschwenken des Auslegers bei Überführungen. Das 22,6 m lange Gespann durfte bei der Einstellung in Güterzüge mit maximal 80 km/h befördert werden. Die Hauptaufgaben dieser Kräne bildeten das Einsetzen von Fahrzeugen ins Gleis, Brückenbaustellen und Umladungen, wobei sich mit der Zusammenarbeit zweier Kräne auch die schwersten Loks zurück ins Gleis setzen ließen. Für den nötigen Antrieb sorgte im Dampfkran eine umsteuerbare liegende, 75 PS starke Zweizylinder Dampfmaschine. Alle vier Kräne wurden 1978/79 ausgemustert, doch einer blieb im Auto & Technik Museum Sinsheim erhalten. Dort kann der ehemalige „6600 Mainz“ mit angehängter Dampfspeicherlokomotive bewundert werden.

Information about the prototype

Maintenance and expansion of a rail network are essential for smooth railroad operations. Among the work required for this are the changing out of turnouts, the trimming of trees that have grown too high, or the rerailing of locomotives and cars. After accidents, locomotives and cars must be salvaged, rubble has to be removed, and rescue measures often have to be led quickly and efficiently under enormous time constraints. The conditions for this are often only suboptimal or simply bad. Sometimes a rail line has no road next to it or it is completely isolated such as in tunnels, on grades, or in deep cuts in the landscape. Often there is also a quantity of obstacles such as catenary, station platforms, masts, pillars and poles, or signal installations to manage. The railroad therefore needs cranes specially adapted to perfection for its requirements. These units must ensure appropriate maneuverability and mobility on the track with and without a load, efficient power for lifting, supporting, positioning, and excellent maneuverability even in tricky areas difficult to access.

There was a lot to clear away in the Western Zones after World War II and the DRG thus ordered four steam cranes in 1948 from the firm Ardelt. These units had a lifting capacity of 57 metric tons and were delivered in 1949. They were rostered by the just established DB as Essen 6660, Mainz 6600, München 6664, and Wuppertal 6602. These cranes were designed in such a way that their counterweight could be stored on the sub-frame of the crane car and the lower parts of the counterweight could be stored by means of two spool wheels in the "hawker's tray" between

the buffer beam and support arm pivots. This allowed an adequate boom swing on this six-axle unit without exceeding the center axle load of 18 metric tons and an acceptable support width of six meters / 19 feet 6 inches while still maintaining a maximum lifting capacity of 57 metric tons. During transport, the smoke stack addition merely had to be removed and secured behind and above the weights. The crane car's total weight was 106 metric tons. A stake car put in front with a mounting block as a boom tender prevented the boom from swinging out during transport. This 22.6 meter / 73 foot 5 inch long team was allowed a maximum speed of 80 km/h / 50 mph when used in freight trains. The main tasks of these cranes were placing locomotives and cars on the track, bridge construction sites, and reloading, whereby even the heaviest locomotives could be put back on the track by two cranes working together. A reversible 75 horsepower two-cylinder steam engine in the steam-powered crane provided the required drive mechanism. All four cranes were retired in 1978/79, but one remains preserved at the Auto & Technology Museum in Sinsheim. The former "6600 Mainz" can be admired there coupled to a fireless steam locomotive.

Informations concernant la locomotive réelle

Pour une exploitation ferroviaire fiable, l'entretien et l'aménagement du réseau de voies sont essentiels. Comptent entre autres parmi les tâches nécessaires le remplacement d'appareils de voie, la taille des arbres ou l'enraillement de locomotives et de wagons. Après un accident, locomotive et wagons doivent être sécurisés, les débris évacués et des mesures de sauvetage prises, le tout rapidement et efficacement, bien souvent dans une extrême urgence. Or, les conditions-cadres laissent souvent à désirer, voire sont simplement mauvaises. Parfois, aucune route ne permet d'accéder à la ligne ferroviaire concernée qui peut même être totalement isolée comme dans les tunnels, les sections à forte déclivité ou les vallées. Souvent il faut également surmonter un grand nombre d'obstacles tels que caténaires, quais, mâts, poteaux ou dispositifs de signalisation. Les chemins de fer ont donc besoin de grues parfaitement adaptées à leurs besoins, capables de garantir entre autres la mobilité et la maniabilité nécessaires sur la voie, avec ou sans charge, un levage, étayage et positionnement efficaces ainsi qu'une excellente manœuvrabilité, même dans les zones difficilement accessibles et les situations « épineuses ».

Après la seconde guerre mondiale, il y avait beaucoup à déblayer dans les zones occidentales. C'est pourquoi la DRG commanda en 1948 à la firme Ardelt quatre grues à vapeur d'une capacité de charge de 57 tonnes, qui furent livrées en 1949 et immatriculées par la DB – tout juste fondée – sous les désignations Essen 6660, Mainz 6600, München 6664 et Wuppertal 6602. Ces grues étaient conçues de telle sorte

que, durant le transport, leur contre-poids pouvait être déposé sur le wagon de transport et que les parties inférieures du contre-poids, grâce aux deux roues du treuil, pouvaient être casées dans « l'éventaire », entre la traverse porte-tamppons et les charnières des paliers supports. Ainsi, on parvint à réaliser pour l'engin à six essieux - sans dépasser la charge moyenne par essieu de 18 t, une portée convenable et une largeur d'appui acceptable de six mètres - une force maximale de tout de même 57 t. Lors d'un déplacement, il suffisait d'enlever la réhausse de cheminée dépassant le gabarit de libre passage et de la fixer à l'arrière, au-dessus des poids. Le wagon-grue avait un poids total de 106 t. Un wagon à ranchers avec bloc-support placé devant comme wagon de protection empêchait toute rotation de la flèche lors des déplacements. S'il était incorporé dans des trains marchandises, l'attelage de 22,6 mètres de long ne devait pas dépasser la vitesse de 80 km/h.

Ces grues étaient essentiellement utilisées pour l'enraillement d'engins, pour des chantiers de ponts et des transbordements, la combinaison de deux grues permettant de remettre sur les rails même les locomotives les plus lourdes. Dans la grue à vapeur, une machine à vapeur réversible de 75 ch à deux cylindres assurait l'entraînement nécessaire. Les quatre grues furent toutes réformées en 1978/79, mais une fut conservée dans le musée de l'automobile et de la technique de Sinsheim. L'ancienne « 6600 Mainz » peut donc encore y être admirée avec la locomotive à accumulateur de vapeur à laquelle elle est attelée.

Informatie van het voorbeeld

Voor een probleemloze spoorweguitbating zijn het in stand houden en de uitbouw van het spoornet onontbeerlijk. Tot de hiertoe noodzakelijke werkzaamheden behoren o.a. het vervangen van wissels, het snoeien van hoogstambomen of het op de sporen plaatsen van de locomotieven en rijtuigen. Na een ongeval moeten de locomotieven en de wagens worden geborgen, wrakstukken worden weggehaald en reddingswerken vaak onder enorme tijdsdruk snel en efficiënt in goede banen worden geleid. Daarbij zijn de kadervoorwaarden vaak slechts ondermaats of gewoonweg alleen maar slecht: Vaak heeft een spoorwegtraject geen ernaast lopende weg of is die volledig geïsoleerd, zoals in tunnels, bij steile hellingen of diepe kloven. Bovendien zijn er ook een groot aantal hindernissen, zoals bovenleidingen, perrons, masten, palen of signaalinstallaties die men moet overwinnen. Daarom hebben de spoorwegen perfect op hun vereisten afgestemde kranen nodig, die onder andere een passende beweeglijkheid en rijdbaarheid met en zonder last op het spoor, een efficiënt hefvermogen, goede ondersteuning en positionering en een uitstekende manoeuvreerbaarheid garanderen, zelfs in moeilijk toegankelijke of netelige gebieden.

Na de tweede wereldoorlog moest er in de westelijke zones heel wat worden opgeruimd. Daarom bestelde de DRG bij de firma Ardel in 1948 vier stoomkranen met een draagvermogen van 57 ton, die in 1949 werden geleverd en door de pas opgerichte DB als Essen 6660, Mainz 6600, München 6664 en Wuppertal 6602 werden ingelijfd. Deze kranen waren zo gebouwd dat hun contragewicht bij het transport op

de onderwagen werd gelegd en de onderste delen van het contragewicht door middel van beide haspelwielen in de "buikholte" tussen bufferbalk en steunarmscharnieren konden worden opgeborgen. Bij het zesassige rijtuig realiseerde men op die manier een redelijke vlucht en een draagbare stempelbreedte van zes meter zonder de middelste wielaslast van 18 ton te overschrijden, met in elk geval nog een maximale draagkracht van 57 ton. Bij een overbrenging moest alleen de schoorsteenuitvoering worden afgenomen, omdat die het omgrenzingsprofiel overschreed, en achteraan bovenop de gewichten worden vastgemaakt. Het totale gewicht van de kraanwagen bedroeg 106 ton. Een als schutwagen vooraan opgestelde rongenwagen met lagerbok verhinderde uitzwenken van de kraanarm tijdens het overbrengen. Het 22,6 m lange gespan kon bij inschakeling in goederentreinen met een maximale snelheid van 80 km/u worden vervoerd. De hoofdtaken van deze kranen was het op de sporen brengen van rijtuigen, brugbouwplaatsen en overladingen, waarbij door samenwerking van twee kranen ook de zwaarste locomotieven opnieuw op de sporen konden worden gezet. Een omkeerbare, liggende stoommachine met twee cilinders en een vermogen van 75 pk zorgde voor de nodige aandrijving van de stoomkraan. Alle vier kranen werden in 1978/79 buiten dienst gesteld, maar in het Auto & Technik Museum van Sinsheim bleef er één behouden. Daar kan men de voormalige "6600 Mainz" met bijhorende locomotief met stoomgenerator bewonderen.

Sicherheitshinweise

- Das Modell darf nur mit einem dafür bestimmten Betriebssystem (Märklin Wechselstrom, Märklin Delta, Märklin Digital oder DCC) eingesetzt werden.
- Nur Schaltnetzteile und Transformatoren verwenden, die Ihrer örtlichen Netzspannung entsprechen.
- Das Modell darf nur aus einer Leistungsquelle versorgt werden.
- Beachten Sie unbedingt die Sicherheitshinweise in der Bedienungsanleitung zu Ihrem Betriebssystem.
- Setzen Sie das Modell keiner direkten Sonneneinstrahlung, starken Temperaturschwankungen oder hoher Luftfeuchtigkeit aus.
- **ACHTUNG!** Funktionsbedingte scharfe Kanten und Spitzen.
- **WARNUNG! Dieses Produkt enthält Magnete. Das Verschlucken von mehr als einem Magneten kann unter Umständen tödlich wirken. Gegebenenfalls ist sofort ein Arzt aufzusuchen.**
- Verbaute LED`s entsprechen der Laserklasse 1 nach Norm EN 60825-1.

Wichtige Hinweise

- Die Bedienungsanleitung und die Verpackung sind Bestandteile des Produktes und müssen deshalb aufbewahrt sowie bei Weitergabe des Produktes mitgegeben werden.
- Für Reparaturen oder Ersatzteile wenden Sie sich bitte an Ihren Märklin-Fachhändler.
- Gewährleistung und Garantie gemäß der beiliegenden Garantieurkunde.
- Entsorgung: www.maerklin.com/en/imprint.html
- Der befahrbare Mindestradius ist 437 mm.

Funktionen

- Erkennung der Betriebsart: automatisch.
- Mfx-Technologie für Mobile Station / Central Station.
Name ab Werk: **ArdeIt 57t 6664**
- Adresse ab Werk: **MM 77 / DCC 03**
- Einstellen der Lokparameter (Adresse, Anfahr-/Bremsverzögerung, Höchstgeschwindigkeit):
über Control Unit, Mobile Station oder Central Station.
- Spielmodus Lokführer
- Weiterführende Erläuterungen zum Spielmodus finden Sie in der ergänzenden Anleitung (beiliegend).
- Diverse schaltbare Funktionen.

Hinweis:

Das Digital-Protokoll mit den meisten Möglichkeiten ist das höchstwertige Digital-Protokoll. Die Reihenfolge der Digital-Protokolle ist in der Wertung fallend:

Priorität 1: mfx

















Priorität 2: DCC

Priorität 3: MM

Wenn zwei oder mehr digital-Protokolle am Gleis erkannt werden, wählt der Decoder automatisch das höchstwertige Protokoll. Wird z.B. mfx und MM erkannt, wählt der Decoder mfx. Einzelne Protokolle können über den Parameter CV 50 deaktiviert werden.

Ergänzende Hinweise

Beim Fahren des Kranwagens auf der Anlage muss auf eine angemessene Geschwindigkeit geachtet werden. Die Stützen müssen ganz eingeschraubt sein und der Ausleger flach auf dem Auslegerschutzwagen liegen. Siehe Seiten 24 / 25.

Schaltbare Funktionen	 60651 / 60652	 60653 / 60657 Trix 66950 / 66955	 60212 / 60213 60214 / 60215	 60216 / 60226
Arbeitscheinwerfer	Funktion 1	Funktion f0	Funktion f0	Funktion f0
Rauchgenerator	Funktion 7	Funktion f1	Funktion f1	Funktion f1
Betriebsgeräusch	Funktion 2	Funktion f2	Funktion f2	Funktion f2
Kran ausleger heben / senken *	f5 + 	f3 + 	f3 + 	f3 + 
Kran ausleger drehen *	f3 + 	f4 + 	f4 + 	f4 + 
Kranhaken auf / ab *	 + 	f5 + 	f5 + 	f5 + 
Führerstandsbeleuchtung	Funktion 8	Funktion f6	Funktion f6	Funktion f6
Umgebungsgeräusch: Warnsignal Typhon	Funktion 6	Funktion f7	Funktion f7	Funktion f7
Umgebungsgeräusch: Winkelschleifer	Funktion 4	Funktion f8	Funktion f8	Funktion f8
Umgebungsgeräusch: Hämmern	—	Funktion f9	Funktion f9	Funktion f9
Umgebungsgeräusch: Kompressor	—	Funktion f10	Funktion f10	Funktion f10

* Arbeitsrichtung umschalten



Auf der MS1 (60651 / 60652) werden keine Funktionssymbole zugewiesen

Safety Notes

- This model is to be used only with an operating system designed for it (Märklin AC, Märklin Delta, Märklin Digital or DCC).
- Use only switched mode power supply units and transformers that are designed for your local power system.
- This model must never be supplied with power from more than one transformer.
- Pay close attention to the safety notes in the instructions for your operating system.
- Do not expose the model to direct sunlight, extreme changes in temperature, or high humidity.
- **WARNING!** Sharp edges and points required for operation.
- **WARNING! This product contains magnets. Swallowing more than one magnet may cause death in certain circumstances. If necessary, see a doctor immediately.**
- The LEDs in this item correspond to Laser Class 1 according to Standard EN 60825-1.

Important Notes

- The operating instructions and the packaging are a component part of the product and must therefore be kept as well as transferred along with the product to others.
- Please see your authorized Märklin dealer for repairs or spare parts.
- The warranty card included with this product specifies the warranty conditions.
- Disposing: www.maerklin.com/en/imprint.html
- The minimum usable radius is 437 mm / 17-1/4".

Functions

- Recognition of the mode of operation: automatic.
- Mfx technology for the Mobile Station / Central Station. Name set at the factory: **Ardelt 57t 6664**
- Address set at the factory: **MM 77 / DCC 03**
- Setting the locomotive parameters (address, acceleration/braking delay, maximum speed): with the Control Unit, Mobile Station, Central Station.
- Mode of Operation: Locomotive Engineer
- Additional explanations about the mode of operation can be found in the supplemental instructions (included).
- Various controllable functions.

Note:











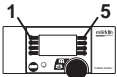





The digital protocol with the most possibilities is the highest order digital protocol. The sequence of digital protocols in descending order is:

- Priority 1: mfx
- Priority 2: DCC
- Priority 3: MM

If two or more digital protocols are recognized in the track, the decoder automatically takes on the highest value digital protocol. For example, if mfx & MM are recognized, the mfx digital protocol is taken on by the decoder. Individual protocols can be deactivated with Parameter CV 50.

Supplemental Notes

Moderate speed must be maintained when running the crane car on a layout. The supports must be screwed in place completely, and the boom must lie flat on the boom tender car. See Pages 24 / 25.

Controllable Functions	 60651 / 60652	 60653 / 60657 Trix 66950 / 66955	 60212 / 60213 60214 / 60215	 60216 / 60226
Working lights	Function 1	Function f0	Function f0	Function f0
Smoke generator	Function 7	Function f1	Function f1	Function f1
Sound effect: Operating sounds	Function 2	Function f2	Function f2	Function f2
Raising / lowering crane boom *	f5 + 	f3 + 	f3 + 	f3 + 
Turning crane boom *	f3 + 	f4 + 	f4 + 	f4 + 
Crane hook up / down *	 + 	f5 + 	f5 + 	f5 + 
Engineer's cab lighting	Function 8	Function f6	Function f6	Function f6
Surrounding sounds: Warning horn	Function 6	Function f7	Function f7	Function f7
Surrounding sounds: Angle grinder	Function 4	Function f8	Function f8	Function f8
Surrounding sounds: Hammering	—	Function f9	Function f9	Function f9
Surrounding sounds: Compressor	—	Function f10	Function f10	Function f10

* Changing the direction of the work being performed



No function symbols are shown on the MS1 (60651 / 60652)

Remarques importantes sur la sécurité

- Le modèle ne peut être mise en service qu'avec un système d'exploitation adéquat (Märklin AC, Märklin Delta, Märklin Digital ou DCC).
- Utiliser uniquement des convertisseurs et transformateurs correspondant à la tension du secteur local.
- Le modèle ne peut être alimentée en courant que par une seule source de courant.
- Veuillez impérativement respecter les remarques sur la sécurité décrites dans le mode d'emploi de votre système d'exploitation.
- Ne pas exposer le modèle à un ensoleillement direct, à de fortes variations de température ou à un taux d'humidité important.
- **ATTENTION!** Pointes et bords coupants lors du fonctionnement du produit.
- **ATTENTION ! Ce produit contient des aimants. L'ingestion de plusieurs aimants peut être mortelle. Le cas échéant, consulter immédiatement un médecin.**
- Les DEL installées correspondent à la classe laser 1 selon la norme EN 60825-1.

Information importante

- La notice d'utilisation et l'emballage font partie intégrante du produit ; ils doivent donc être conservés et, le cas échéant, transmis avec le produit.
- Pour toute réparation ou remplacement de pièces, adressez-vous à votre détaillant-spécialiste Märklin.
- Garantie légale et garantie contractuelle conformément au certificat de garantie ci-joint.
- Elimination : www.maerklin.com/en/imprint.html
- Le rayon minimum de déplacement est de 437 mm.

Fonctionnement

- Détection du mode d'exploitation : automatique.
- Technologie mfx pour Mobile Station / Central Station.
Nom en codee en usine: **Ardelt 57t 6664**
- Adresse encodée en usine: **MM 77 / DCC 03**
- Réglage des paramètres de la loco (adresse, temporisation accélér.-freinage, vitesse maximale) : via Control Unit, Mobile Station ou Central Station.
- Mode de jeu «Conducteur de train»
- Vous trouverez de plus amples informations concernant le mode de jeu dans la notice complémentaire (ci-jointe).
- Diverses fonctions commutables.

Remarque:

















Le protocole numérique offrant les possibilités les plus nombreuses est le protocole numérique à bit de poids fort. La hiérarchisation des protocoles numériques est descendante :

- Priorité 1 : mfx
- Priorité 2 : DCC
- Priorité 3 : MM

Si deux ou plus de deux protocoles numériques sont reconnus sur la voie, le décodeur choisit automatiquement le protocole numérique le plus significatif. Entre les protocoles mfx & DCC par exemple, le décodeur choisira le protocole numérique mfx. Vous pouvez désactiver les différents protocoles via le paramètre CV 50.

Indication complémentaire

Lors de la circulation du wagon-grue sur le réseau, respecter une vitesse adaptée. Les supports doivent être entièrement vissés et la flèche doit reposer à plat sur le wagon de protection. Voir pages 24 et 25.

Fonctions commutables	 60651 / 60652	 60653 / 60657 Trix 66950 / 66955	 60212 / 60213 60214 / 60215	 60216 / 60226
Feux de travail	Fonction 1	Fonction f0	Fonction f0	Fonction f0
Générateur de fumée	Fonction 7	Fonction f1	Fonction f1	Fonction f1
Bruitage : Bruit d'exploitation	Fonction 2	Fonction f2	Fonction f2	Fonction f2
Lever / Abaisser la flèche de la grue *	f5 + 	f3 + 	f3 + 	f3 + 
Faire pivoter la flèche de la grue *	f3 + 	f4 + 	f4 + 	f4 + 
Lever / Abaisser le crochet de la grue *	 + 	f5 + 	f5 + 	f5 + 
Eclairage de la cabine de conduite	Fonction 8	Fonction f6	Fonction f6	Fonction f6
Bruitage environnement : Signal acoustique de danger	Fonction 6	Fonction f7	Fonction f7	Fonction f7
Bruitage environnement : Meuleuse d'angle	Fonction 4	Fonction f8	Fonction f8	Fonction f8
Bruitage environnement : Coups de marteau	—	Fonction f9	Fonction f9	Fonction f9
Bruitage environnement : Compresseur	—	Fonction f10	Fonction f10	Fonction f10

* Inverser le sens du mouvement



Sur la MS1 (60651 / 60652) n'est attribué aucun symbole de fonction

Veiligheidsvoorschriften

- Dit model mag alleen met een daarvoor bestemd bedrijfs-systeem (Märklin AC, Märklin Delta, Märklin digitaal of DCC) gebruikt worden.
- Alleen net-adapters en transformatoren gebruiken waarvan de aangegeven netspanning overeenkomt met de netspanning ter plaatse.
- Dit model mag niet vanuit meer dan één stroomvoorziening gelijktijdig gevoed worden.
- Lees ook aandachtig de veiligheidsvoorschriften in de gebruiksaanwijzing van uw bedrijfssysteem.
- Stel het model niet bloot aan in directe zonnestraling, sterke temperatuurwisselingen of hoge luchtvochtigheid.
- **OPGEPAST!** Functionele scherpe kanten en punten.
- **LET OP! Dit product bevat magneten. Het inslikken van meer dan één magneet kan onder bepaalde omstandigheden de dood tot gevolg hebben. Waarschuw direct een arts.**
- Ingebouwde LED's komen overeen met de laserklasse 1 volgens de norm EN 60825-1.

Belangrijke aanwijzing

- De gebruiksaanwijzing en de verpakking zijn een bestanddeel van het product en dienen derhalve bewaard en meegeleverd te worden bij het doorgeven van het product.
- Voor reparatie of onderdelen kunt u zich tot uw Märklin handelaar wenden.
- Vrijwaring en garantie overeenkomstig het bijgevoegde garantiebewijs.
- Afdanken: www.maerklin.com/en/imprint.html
- De berijdbare minimum radius bedraagt 437 mm.

Funcities

- Herkenning van het bedrijfssysteem: automatisch.
- Mfx-technologie voor het Mobile Station / Central Station. Naam af de fabriek: **Ardelt 57t 6664**
- Vanaf de fabriek ingesteld: **MM 77 / DCC 03**
- Instellen van de locomotiefparameters (adres, optrekafremvertraging, maximumsnelheid): d.m.v. Control Unit, Mobile Station of Central Station.
- Speelmodus machinist
- Verdere aanwijzingen voor deze speelmodus vindt u in de bijgevoegde uitgebreide gebruiksaanwijzing.
- Diverse schakelbare functies.

Opmerking:

Het digitaalprotocol met de meeste mogelijkheden is het primaire digitaalprotocol. De volgorde van de digitaalprotocollen is afnemend in mogelijkheden:

Prioriteit 1: mfx











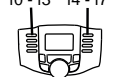





Prioriteit 2: DCC

Prioriteit 3: MM

Als er twee of meer digitale protocollen op de rails worden herkend, dan neemt de decoder automatisch het hoogwaardigste protocol over; bijv. word mfx & MM herkend, dan wordt het mfx signaal door de decoder overgenomen. De verschillende protocollen kunnen via de parameter CV 50 gedeactiveerd worden.

Extra opmerking

Bij het rijden met de kraanwagen op de modelbaan dien u er op te letten dat dit met een aangepaste snelheid gebeurt. De steunen moeten volledig ingedraaid zijn en de giek moet vlak op de giek ondersteuningswaggen liggen. Zie pagina 24 / 25.

Schakelbare functies	 60651 / 60652	 60653 / 60657 Trix 66950 / 66955	 60212 / 60213 60214 / 60215	 60216 / 60226
Werkschijnwerper	Functie 1	Functie f0	Functie f0	Functie f0
Rookgenerator	Functie 7	Functie f1	Functie f1	Functie f1
Geluid: bedrijfsgeluiden	Functie 2	Functie f2	Functie f2	Functie f2
Kraangiek heffen / vieren *	f5 + 	f3 + 	f3 + 	f3 + 
Kraangiek draaien *	f3 + 	f4 + 	f4 + 	f4 + 
Kraanhaak heffen / vieren *	 + 	f5 + 	f5 + 	f5 + 
Cabineverlichting	Functie 8	Functie f6	Functie f6	Functie f6
Omgevingsgeluid: waarschuwingshoorn	Functie 6	Functie f7	Functie f7	Functie f7
Omgevingsgeluid: haakse slijper	Functie 4	Functie f8	Functie f8	Functie f8
Omgevingsgeluid: hameren	—	Functie f9	Functie f9	Functie f9
Omgevingsgeluid: compressor	—	Functie f10	Functie f10	Functie f10

* Richting omkeren



Op de MS1 (60651 / 60652) worden geen functiesymbolen weergegeven

Aviso de seguridad

- Este modelo solamente debe funcionar en un sistema de corriente propio (Märklin AC – Märklin Delta – Märklin Digital o DCC).
- Emplear únicamente fuentes de alimentación conmutadas y transformadores que sean de la tensión de red local.
- La alimentación de la modelo deberá realizarse desde una sola fuente de suministro.
- Observe bajo todos los conceptos, las medidas de seguridad indicadas en las instrucciones de su sistema de funcionamiento.
- No exponer el modelo en miniatura a la radiación solar directa, a oscilaciones fuertes de temperatura o a una humedad del aire elevada.
- **¡ATENCIÓN!** Esquinas y puntas afiladas condicionadas a la función.
- **¡ ADVERTENCIA ! Este producto contiene imanes. Ingerir más de un imán puede ser mortal según las circunstancias. En este caso, acudir inmediatamente a un médico.**
- Los LEDs incorporados corresponden a la clase de láser 1 según la norma europea EN 60825-1.

Notas importantes

- Las instrucciones de empleo y el embalaje forman parte íntegra del producto y, por este motivo, deben guardarse y entregarse junto con el producto en el caso de venderlo o transmitirlo a otro.
- Para reparaciones o recambios contacte con su proveedor Märklin especializado.
- Responsabilidad y garantía conforme al documento de garantía que se adjunta.
- Eliminación: www.maerklin.com/en/imprint.html
- El radio mínimo transitable es de 437 mm.

Funciones

- Reconocimiento del sistema: automático.
- Tecnología mfx para la Mobile Station / Central Station.
Nombre de fabrica: **Ardelt 57t 6664**
- Código de fábrica: **MM 77 / DCC 03**
- Fijar parámetros de la locomotora (código, arranque y frenado, velocidad máxima): por el Control Unit, Mobile Station o Central Station.
- Modo de juego Maquinista
- Encontrará explicaciones adicionales sobre el modo de juego en Internet, en www.maerklin.de <Service> <Anleitungen> <Spielwelt Anleitungen>
- Diversas funciones gobernables.

Nota:

El protocolo digital que ofrece el mayor número de posibilidades es el protocolo digital de mayor peso. El orden de pesos de los protocolos digitales es descendente.:

Prioridad 1: mfx











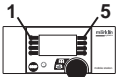





Prioridad 2: DCC

Prioridad 3: MM

Si se detectan en la vía dos o varios protocolos digitales, el decoder asume automáticamente el protocolo digital de mayor valor; p. ej., si se detecta mfx y MM, el decoder asume el protocolo digital mfx. Los distintos protocolos se pueden desactivar mediante el parámetro CV 50.

Indicaciones complementarias

Durante la circulación del vagón grúa por la maqueta hay que asegurar una velocidad razonable. Los apoyos deben estar totalmente atornillados y la pluma debe quedar plana sobre el vagón de protección de la pluma. Ver páginas 24 / 25.

Funciones conmutables	 60651 / 60652	 60653 / 60657 Trix 66950 / 66955	 60212 / 60213 60214 / 60215	 60216 / 60226
Faro de trabajo	Función 1	Función f0	Función f0	Función f0
Generador de humo	Función 7	Función f1	Función f1	Función f1
Ruido: Ruido de explotación	Función 2	Función f2	Función f2	Función f2
Subir / bajar pluma de grúa *	f5 + 	f3 + 	f3 + 	f3 + 
Girar pluma de grúa *	f3 + 	f4 + 	f4 + 	f4 + 
Subir / bajar gancho de grúa *	 + 	f5 + 	f5 + 	f5 + 
Alumbrado interior de la cabina	Función 8	Función f6	Función f6	Función f6
Ruido ambiental: Señal de alarma de tífón	Función 6	Función f7	Función f7	Función f7
Ruido ambiental: Esmeriladora acodada	Función 4	Función f8	Función f8	Función f8
Ruido ambiental: Martilleo	—	Función f9	Función f9	Función f9
Ruido ambiental: Compresor	—	Función f10	Función f10	Función f10

* Cambio del sentido de marcha



En la MS1 (60651 / 60652) no se asignan iconos de funciones

Avvertenze per la sicurezza

- Tale modello deve essere impiegata soltanto con un sistema di funzionamento adeguato per questa (Märklin AC, Märklin Delta, Märklin Digital oppure DCC).
- Impiegare soltanto alimentatori „switching“ e trasformatori che corrispondono alla Vostra tensione di rete locale.
- La modello non deve venire alimentata nello stesso tempo con più di una sorgente di potenza.
- Vogliate prestare assolutamente attenzione alle avvertenze di sicurezza nelle istruzioni di impiego per il Vostro sistema di funzionamento.
- Non esponete tale modello ad alcun irraggiamento solare diretto, a forti escursioni di temperatura oppure a elevata umidità dell'aria.
- **AVVERTENZA!** Per motivi funzionali i bordi e le punte sono spigolosi.
- **AVVERTIMENTO! Questo prodotto contiene magneti. L'ingestione di più di un magnete può causare la morte. In caso di ingestione informare immediatamente un medico.**
- I LED incorporati corrispondono alla categoria di laser 1 secondo la Norma EN 60825-1.

Avvertenze importanti

- Le istruzioni di impiego e l'imballaggio costituiscono un componente sostanziale del prodotto e devono pertanto venire conservati nonché consegnati insieme in caso di ulteriore cessione del prodotto.
- Per le riparazioni o le parti di ricambio, contrattare il rivenditore Märklin.
- Prestazioni di garanzia e garanzia in conformità all'accluso certificato di garanzia.
- Smaltimento: www.maerklin.com/en/imprint.html
- Il raggio minimo percorribile è di 437 mm.

Funzioni

- Riconoscimento del tipo di funzionamento: automatico
- Tecnologia mfx per Mobile Station / Central Station.
Nome di fabbrica: **Ardelt 57t 6664**
- Indirizzo di fabbrica: **MM 77 / DCC 03**
- Regolazione dei parametri della locomotiva (indirizzo, ritardo di avviamento/frenatura, velocità massima): tramite Control Unit, Mobile Station oppure Central Station.
- Modalità di Gioco Macchinista
- Ulteriori esemplificazioni sulla modalità di gioco potete trovarle in Internet sotto www.maerklin.de <Service> <Anleitungen> <Spielewelt Anleitungen>
- Svariate funzionalità commutabili.

Avvertenza:

Il protocollo Digital con il maggior numero di possibilità è il protocollo digitale di massimo valore. La sequenza dei protocolli Digital, con valori decrescenti, è:

Priorità 1: mfx

















Priorità 2: DCC

Priorità 3: MM

Qualora sul binario vengano riconosciuti due o più protocolli digitali, il Decoder assume automaticamente il protocollo digitale con il valore più elevato; ad es. se viene riconosciuto mfx & MM, viene assunto dal Decoder il protocollo digitale mfx. I singoli protocolli possono venire disattivati mediante il parametro CV 50.

Avvertenze supplementari

Durante la marcia del carro gru sull'impianto deve venire rispettata una velocità appropriata. Gli appoggi devono essere del tutto avvitati in dentro ed il braccio deve giacere appiattito sul carro di scudo del braccio. Si vedano le pagine 24 / 25.

Funzioni commutabili	 60651 / 60652	 60653 / 60657 Trix 66950 / 66955	 60212 / 60213 60214 / 60215	 60216 / 60226
Proiettore da lavoro	Funzione 1	Funzione f0	Funzione f0	Funzione f0
Apparato fumogeno	Funzione 7	Funzione f1	Funzione f1	Funzione f1
Rumore: rumori di esercizio	Funzione 2	Funzione f2	Funzione f2	Funzione f2
Sollevare / abbassare il braccio della gru *	f5 + 	f3 + 	f3 + 	f3 + 
Far ruotare il braccio della gru *	f3 + 	f4 + 	f4 + 	f4 + 
Sollevare / rilasciare il gancio della gru *	 + 	f5 + 	f5 + 	f5 + 
Illuminazione della cabina	Funzione 8	Funzione f6	Funzione f6	Funzione f6
Rumore di ambiente: segnale di avvertimento Typhon	Funzione 6	Funzione f7	Funzione f7	Funzione f7
Rumore di ambiente: smerigliatrice angolare	Funzione 4	Funzione f8	Funzione f8	Funzione f8
Rumore di ambiente: martellamento	—	Funzione f9	Funzione f9	Funzione f9
Rumore di ambiente: Compressore	—	Funzione f10	Funzione f10	Funzione f10

* Commutazione della direzione di lavoro



Sulla MS1 (60651 / 60652) non viene assegnato alcun simbolo di funzione

Säkerhetsanvisningar

- Denna modell får endast köras med ett därtill avsett driftsystem (Märklin AC, Märklin Delta, Märklin Digital eller DCC).
- Använd endast nätadapterar och transformatorer anpassade för det lokala elnätet.
- Denna modell får inte samtidigt försörjas av mer än en kraftkälla.
- Beakta alltid säkerhetsanvisningarna i bruksanvisningen som hör till respektive driftsystemet.
- Modellen får inte utsättas för direkt solljus, häftiga temperaturväxlingar eller hög luftfuktighet.
- **WARNING!** Funktionsbetingade vassa kanter och spetsar.
- **WARNING! Denna produkt innehåller magneter. Sväljandet av mer än en magnet kan under vissa omständigheter leda till döden. Om en magnet svalts: Sök omedelbart läkarhjälp.**
- Inbyggda LED (lysdioder) motsvarar laser-klass 1 enligt Ennorm 60825-1

Viktig information

- Bruksanvisningen och förpackningen är en del av produkten och måste därför sparas och alltid medfölja produkten.
- Kontakta din Märklinfackhandlare för reparationer och reservdelar.
- Garantivillkor framgår av bifogade garantibevis.
- Hantering som avfall: www.maerklin.com/en/imprint.html
- Användbar minsta kurvradie är 437 mm.

Funktioner

- Driftsättet igenkänns automatiskt.
- Mfx-teknologi för Mobile Station / Central Station. Namn från tillverkaren: **Ardelt 57t 6664**
- Adress från tillverkaren: **MM 77 / DCC 03**
- Inställning av lokparametrar (Adress, acceleration/bromsfördröjning, toppfart): Via Control Unit, Mobile Station eller Central Station.
- Spelmodus Lokförare
- Ytterligare förklaringar till Simulator-inställningar återfinns på Internet: www.maerklin.de <Service> <Anleitungen> <Spielewelt Anleitungen>
- Olika inställbara funktioner.

Observera:











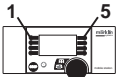





Digital-protokollet med flest funktioner är högst prioriterat. Digital-protokollen inordnas i fallande ordning som följer:

- Prioritet 1: mfx
- Prioritet 2: DCC
- Prioritet 3: MM

Om två eller flera digital-protokoll används via spåret, så använder dekodern automatiskt det högvärdigaste protokollet. Används t. ex. mfx & MM, så kommer dekodern att använda mfx-digital-protokollet. Enstaka protokoll kan avaktiveras med hjälp av CV 50.

Kompletterande information

När man kör kranvagnen på anläggningen måste man hålla en begränsad hastighet. Kranens stöttor måste vara helt inskruvade och kranarmen måste ligga ner ordentligt på kranarmsvagnen. Se sidorna 24 / 25.

Kopplingsbara funktioner	 60651 / 60652	 60653 / 60657 Trix 66950 / 66955	 60212 / 60213 60214 / 60215	 60216 / 60226
Arbetsstrålkastare	Funktion 1	Funktion f0	Funktion f0	Funktion f0
Röksats	Funktion 7	Funktion f1	Funktion f1	Funktion f1
Ljud: Trafikljud	Funktion 2	Funktion f2	Funktion f2	Funktion f2
Kranarms-höjning/sänkning *	f5 + 	f3 + 	f3 + 	f3 + 
Kranarms-rotation *	f3 + 	f4 + 	f4 + 	f4 + 
Krankrok av/på *	 + 	f5 + 	f5 + 	f5 + 
Förrhyttsbelysning	Funktion 8	Funktion f6	Funktion f6	Funktion f6
Omgivnings-ljudbild: Varningssignal: Tyfon	Funktion 6	Funktion f7	Funktion f7	Funktion f7
Omgivnings-ljudbild: Vinkelkap	Funktion 4	Funktion f8	Funktion f8	Funktion f8
Omgivnings-ljudbild: Hamrande	—	Funktion f9	Funktion f9	Funktion f9
Omgivnings-ljudbild: Kompressor	—	Funktion f10	Funktion f10	Funktion f10

* Koppla om arbetsriktning



På MS1 (60651 / 60652) visas inga funktionssymboler

Vink om sikkerhed

- Modellen må kun bruges med et driftssystem (Märklin AC, Märklin Delta, Märklin Digital eller DCC), der er beregnet dertil.
- Anvend kun DC-DC-omformere og transformatorer, der passer til den lokale netspænding.
- Modellen må ikke forsynes fra mere end én strømkilde ad gangen.
- Vær under alle omstændigheder opmærksom på de vink om sikkerhed, som findes i brugsanvisningen for Deres driftssystem.
- Modellen må ikke udsættes for direkte sollys, store temperaturudsving eller høj luftfugtighed.
- **ADVARSEL!** Skarpe kanter og spidser pga. funktionen.
- **ADVARSEL! Dette produkt indeholder magneter. Det kan i visse tilfælde have dødelige følger at sluge mere end en magnet. I givet fald skal der straks søges læge.**
- De indbyggede lysdioder svarer til laserklasse 1 i henhold til normen EN 60825-1.

Vigtige bemærkninger

- Betjeningsvejledning og emballage hører til produktet og skal derfor gemmes og medfølge, hvis produktet gives videre til andre.
- For reparation eller reservedele bedes De henvende Dem til Deres Märklinforhandler.
- Garanti ifølge vedlagte garantibevis.
- Bortskafning: www.maerklin.com/en/imprint.html
- Mindsteradius udgør 437 mm.

Funktioner

- Registrering af driftsarten: automatisk.
- Mfx-teknologi til Mobile Station / Central Station.
Navn af fabrik: **Ardelt 57t 6664**
- Adresse af fabrik: **MM 77 / DCC 03**
- Indstilling af lokomotivparametrene (adresse, kørsels-/bremseforsinkelser, maksimalhastighed):
Via Control Unit, Mobile Station eller Central Station.
- Operationsmodus lokomotivfører
- Find flere beskrivelser til legemodus på internettet under www.maerklin.de <Service> <Vejledninger> <Vejledninger legerverden>
- Diverse styrbare funktioner.

Bemærk:

















Digital-protokollen med flest muligheder er den højest rangerende digital-protokol. Digital-protokollernes rækkefølge er med faldende værdi følgende:

- Prioritet 1: mfx
- Prioritet 2: DCC
- Prioritet 3: MM

Genkendes to eller flere digital-protokoller på sporet, overtager dekoderen automatisk den højest rangerende digital-protokol, f.eks. mfx/MM, dermed overtages mfx-digital-protokollen af dekoderen. Enkelte protokoller kan deaktiveres via parameter CV 50.

Tillægsbemærkninger

Ved kørsel med kranvognen på anlægget skal man være opmærksom på en passende hastighed. Støtterne skal være skruet helt ind og udliggøren skal ligge fladt på udliggervognen. Se siderne 24 / 25.

Styrbare funktioner	 60651 / 60652	 60653 / 60657 Trix 66950 / 66955	 60212 / 60213 60214 / 60215	 60216 / 60226
Arbejdslygte	Funktion 1	Funktion f0	Funktion f0	Funktion f0
Røggenerator	Funktion 7	Funktion f1	Funktion f1	Funktion f1
Lyd: Driftslyd	Funktion 2	Funktion f2	Funktion f2	Funktion f2
Løft / sænk kranarm *	f5 + 	f3 + 	f3 + 	f3 + 
Drej kranarm *	f3 + 	f4 + 	f4 + 	f4 + 
Krankrog op/ned *	 + 	f5 + 	f5 + 	f5 + 
Kabinebelysning	Funktion 8	Funktion f6	Funktion f6	Funktion f6
Omgivelseslyd: Advarselssignal tyfon	Funktion 6	Funktion f7	Funktion f7	Funktion f7
Omgivelseslyd: Vinkelsliber	Funktion 4	Funktion f8	Funktion f8	Funktion f8
Omgivelseslyd: Hammer	—	Funktion f9	Funktion f9	Funktion f9
Omgivelseslyd: Kompressor	—	Funktion f10	Funktion f10	Funktion f10

* Skift af arbejdsretning



På MS1 (60651 / 60652) tildeles ingen funktionssymboler

Fahrbetrieb • Running Operation • Circulation • Rijbedrijf • Modo circulación • Esercizio di marcia • Körning • Køredrift

Kranwagen-Zug in Transport-Stellung (siehe auch „Ergänzende Hinweise“ auf Seite 8)

Crane car train ready for transport (See also „Supplemental Notes“ on Page 10)

Train de wagon-grue en position de transport (Voir également « Indication complémentaire » page 12)

Kraanwagentrein in de transportstand (Zie ook “Extra opmerking” op pagina 14)

Convoy de la grúa en posición de transporte (Véase también „Indicaciones complementarias” en página 16)

Treno con carro gru in assetto da trasporto (Si veda anche „Avvertenze supplementari” a pagina 18)

Kranvagnståg i transportläge (Se även “Kompletterande information” på sidan 20)

Kranvognstog i transportstilling (Se også „Tillægsbemærkninger” på side 22)

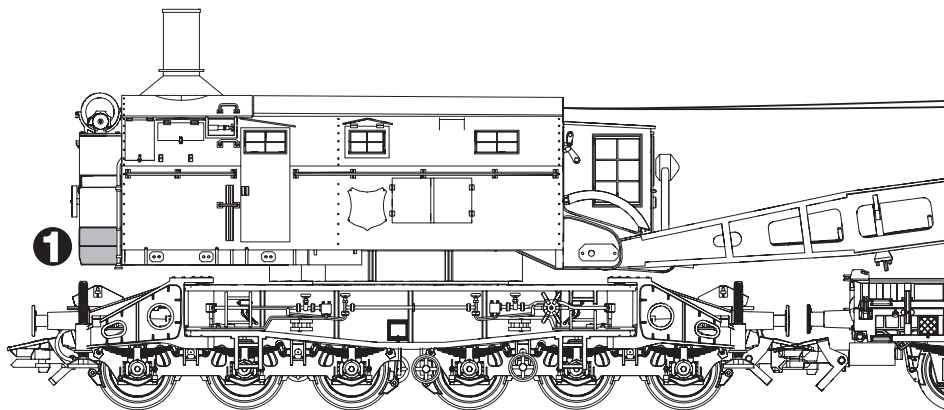

1 Gegengewichte
Counterweights
Contrepoids
Contra-gewichten
Contrapesos
Contrappesi
Motvikter
Kontravægte

2 Stützsockel
Support bases
Socles de stabilisation
Steunsokkels
Zócalos de soporte
Basamenti di supporto
Stödplattor
Støttesokler

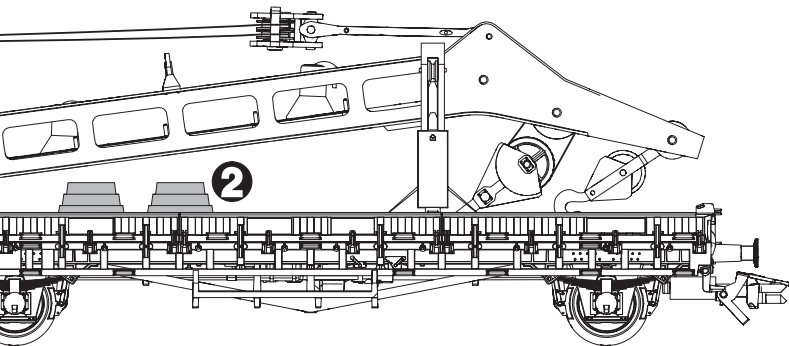

Kranbetrieb • Crane Operation • Exploitation de la grue • Kraanbedrijf • Modo grúa • Esercizio della gru • Krandrift • Krandrift

Stützsockel aufstellen und Stützarme einstellen

Setting up the support bases and adjusting the outrigger support arms

Placer les socles de stabilisation et régler les stabilisateurs

Steunsokkel plaatsen en steunarmen instellen

Montar los zócalos de soporte y ajustar los brazos de soporte

Piazzamento dei basamenti di supporto e installazione dei bracci di appoggio

Stödplattorna placeras och stödben ställs in

Opstil støttesokler. Støttearme indstilles

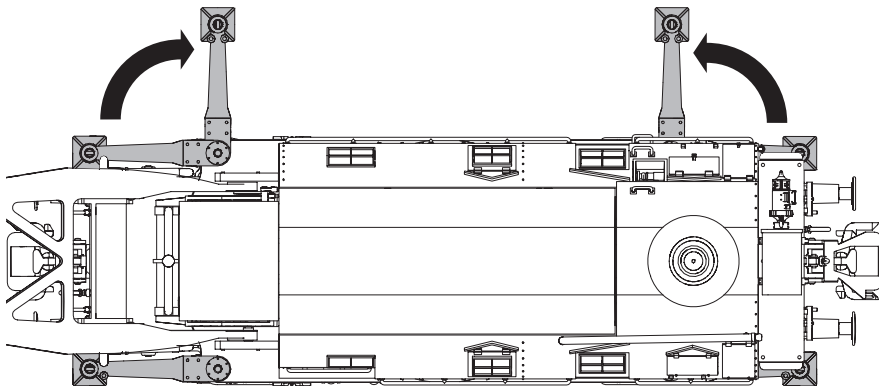

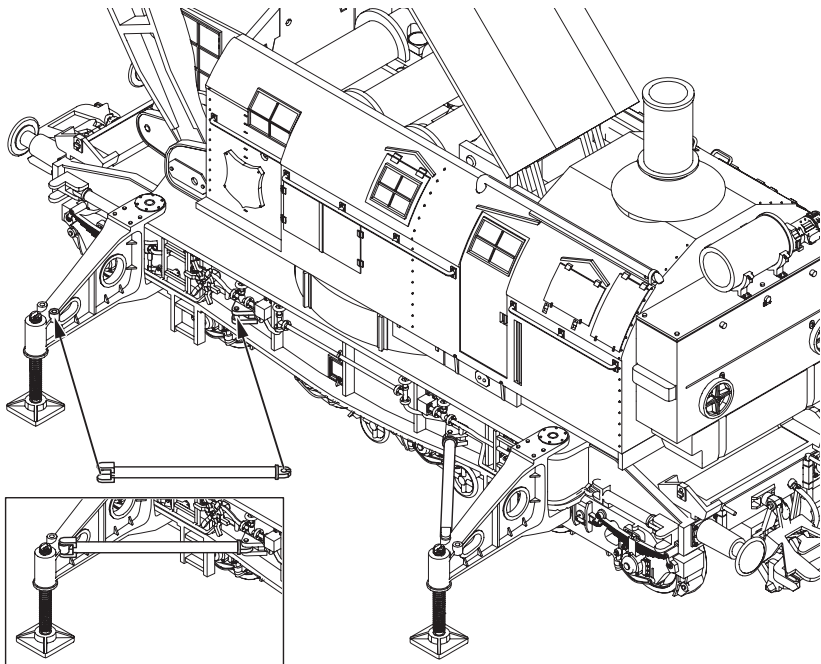

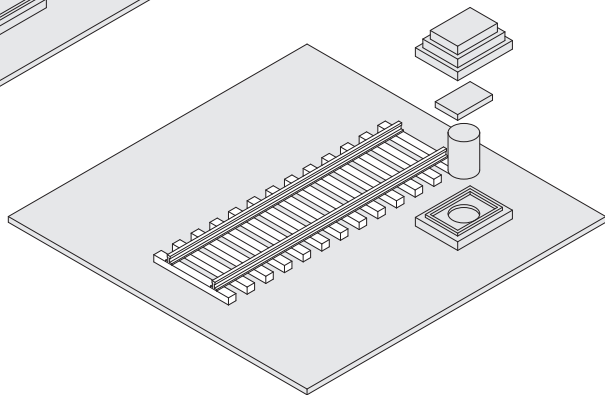
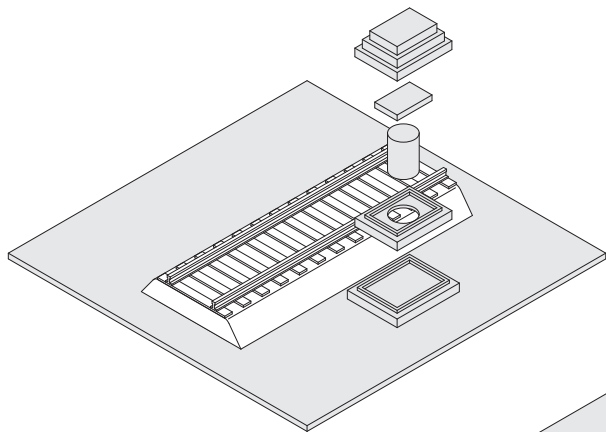

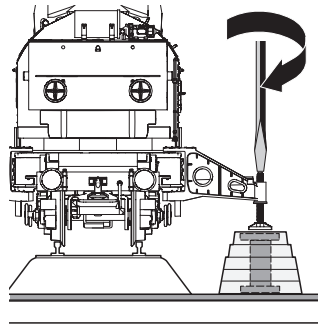
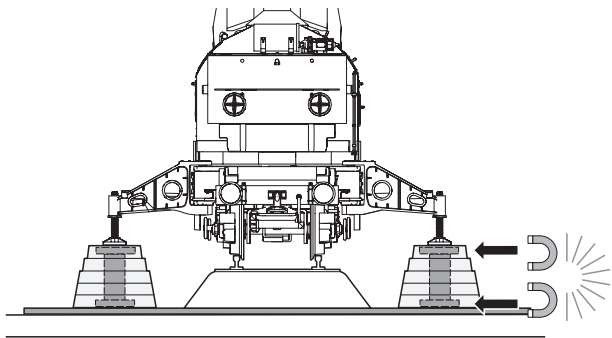

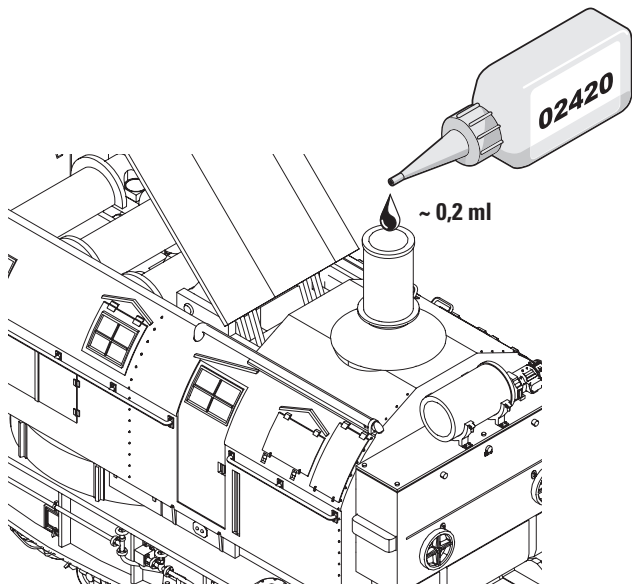

Potentielle Fehlerquellen beim Rauchgenerator

- Der Rauchgenerator darf nur maximal halb mit Rauchöl gefüllt sein.
- Im Rauchgenerator darf sich keine Luftblase befinden.

Potential Problems with the Smoke Generator

- The smoke generator cannot be filled any more than halfway with smoke fluid.
- There should not be any air bubbles in the smoke generator.

Causes d'erreurs potentielles avec le générateur fumigène

- Le générateur fumigène ne peut pas être rempli de liquide fumigène au-delà de la moitié du tube.
- Aucune bulle d'air ne peut se trouver dans le générateur fumigène.

Potentiële storingsoorzaken bij rookgeneratoren

- De rookgenerator mag maximaal half met rookolie gevuld worden.
- In de rookgenerator mag zich geen luchtbel bevinden.

Instrucciones importantes para el buen uso del fumígeno

- Llenar el cartucho solamente hasta la mitad con líquido fumígeno.
- Prestar atención que no se forme una burbuja de aire en el cartucho.

Potenziali origini di guasti nel caso dell'apparato fumogeno

- L'apparato fumogeno come massimo deve essere riempito solamente a metà di olio vaporizzabile.
- Nell'apparato fumogeno non deve trovarsi alcuna bolla d'aria.

Potentiella felkällor på rökgeneratoren

- Rökgeneratoren får maximalt fyllas till hälften med rökvätska.
- I rökgeneratoren får inte finnas någon luftblåsa.

Potentielle fejkilder ved røggeneratoren

- Røggeneratoren må maksimalt være halvt fyldt med røgolie.
- Der må ikke være nogen luftbobler i røggeneratoren.

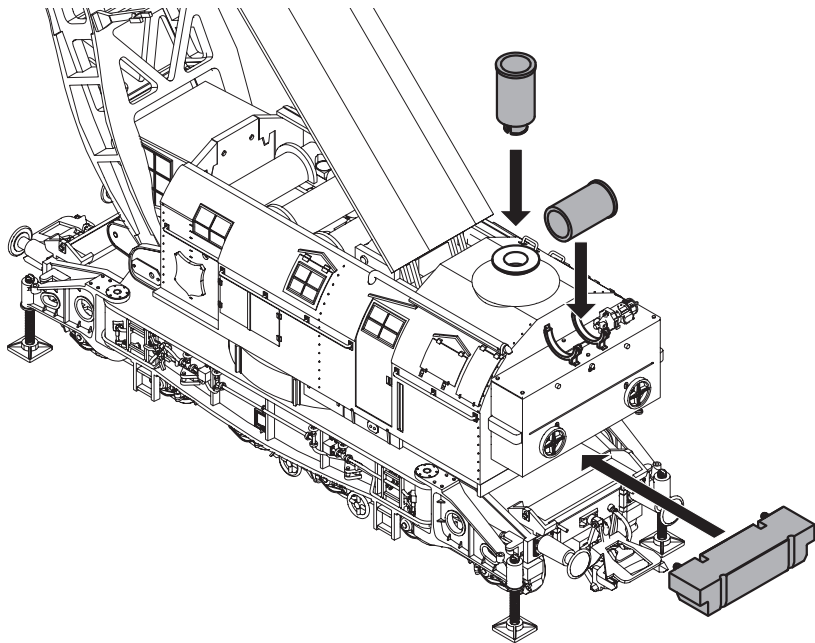

CV (Parameter) • CV (Parameter) • CV (Paramètre) • CV (Parameter) • CV (Parámetro) • CV (Parametro) • CV (Parameter) • CV (Parameter)	CV-Nr.	Wert • Value • Valeur • Waarde • Valor • Valore • Värde • Værdi
Adresse • Address • Adresse • Adres • Código • Indirizzo • Adress • Adresse	01	01 - (80)* 255
Anfahrverzögerung • Acceleration delay • Temporisation accélération • Optrekvertraging • Regulación arranque • Ritardo di avviamento • Igångsättningsreglering • Kørselsforsinkelse	03	01 - (63)* 255
Bremsverzögerung • Braking delay • Temporisation de freinage • Afremvertraging • Frenado lento • Ritardo di frenatura • Bromsfördröjning • Bremseforsinkelse	04	01 - (63)* 255
Höchstgeschwindigkeit • Maximum speed • Vitesse maximale • Maximumsneilheid • Velocidad máxima • Velocità massima • Toppfart • Maksimalhastighed	05	01 - (63)* 255
Rückstellen auf Serienwerte • Reset to series value • Remettre aux valeurs de série • Terugzetten naar serie-instellingen • Restablecer los valores de serie • Ripristinare sui valori di serie • Återställa till standardvärden • Tibagestil til serieværdien	08	08
Alternative Protokolle • Alternative Protocols • Autres protocoles • Alternatieve protocollen • Protocolos alternativos • Protocolli alternativi • Alternativa protokoll • Alternative protokoller	50	0 - 15
Lautstärke • Volume • Volume haut-parleur • Volume • Volumen del sonido • Intensità del suono • Ljudstyrka • Lydstyrke	63	01 - (63)* 255

* () Control Unit 6021/Mobile Station 60651/60652

CV 50 Alternative Protokolle • CV 50 Alternative Protocols • CV 50 Autres protocoles • CV 50 Alternatieve protocollen • CV 50 Protocolos alternativos • CV 50 Protocolli alternativi • CV 50 Alternativa protokoll • CV 50 Alternative protokoller

Analog AC Analog AC Analogique CA Analoog AC Analógico AC Analogico AC Analog AC Analog AC	Analog DC Analog DC Analogique CC Analoog DC Analógico DC Analogico DC Analog DC Analog DC	DCC oder MM DCC or MM DCC ou MM DCC of MM DCC o MM DCC oppure MM DCC eller MM DCC eller MM	mfx	Werte Values Valeurs Waarde Valores Valori Värden Værdier	Hinweis: Das aktuell genutzte Protokoll ist nicht deaktivierbar. Note: The current protocol in use cannot be deactivated. Remarque : Impossible de dés-activer le protocole actuellement utilisé. Opmerking: Het actueel gebruikte protocol kan niet gedeactiveerd worden. Nota: El protocolo actualmente utilizado no se puede desactivar. Avvertenza: Il protocollo attualmente utilizzato non è disattivabile. OBS: Det just nu använda protokollet kan ej avaktiveras. Bemærkning: Den aktuelt anvendte protokol kan ikke genaktiveres.
—	—	—	—	0	
✓	—	—	—	1	
—	✓	—	—	2	
✓	✓	—	—	3	
—	—	✓	—	4	
✓	—	✓	—	5	
—	✓	✓	—	6	
✓	✓	✓	—	7	
—	—	—	✓	8	
✓	—	—	✓	9	
—	✓	—	✓	10	
✓	✓	—	✓	11	
—	—	✓	✓	12	
✓	—	✓	✓	13	
—	✓	✓	✓	14	
✓	✓	✓	✓	15	

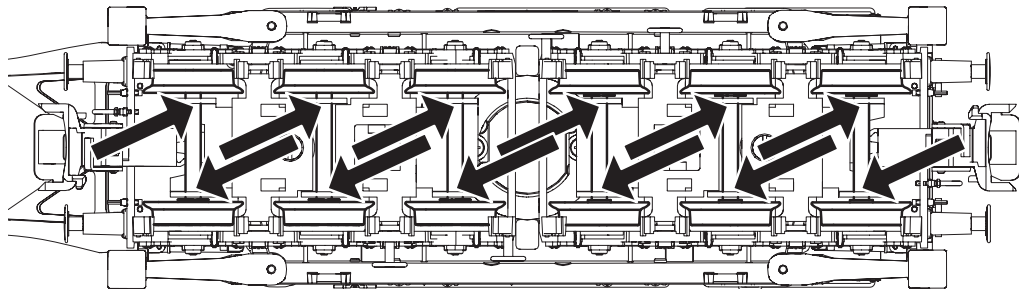

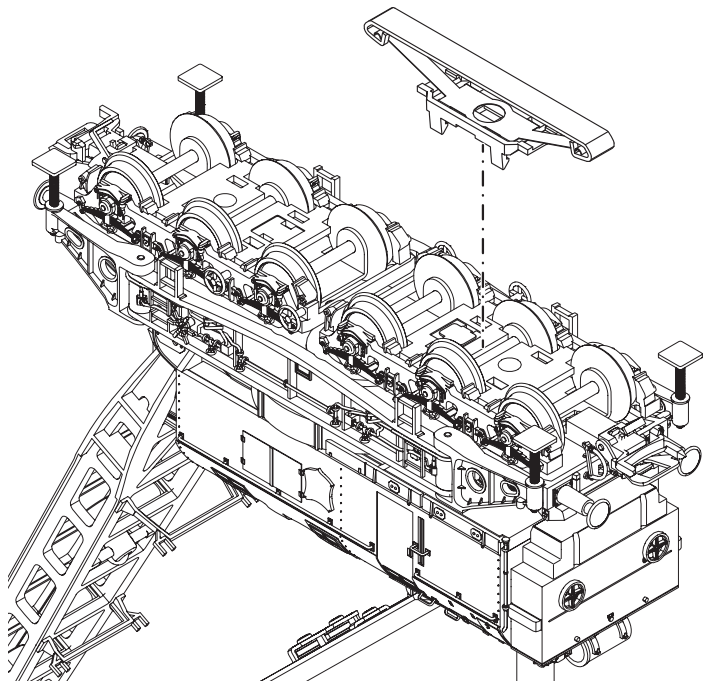
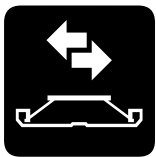

Dampfkran Ardelt

Kamin	E294 728
Kurzkupplung	E701 630
Kupplung	E331 915
Schleifer	E206 370
Zurüst Set	E295 303

Kranschutzwagen

Radsatz	E700 150
Radsatz	E700 580
Kupplungsdeichsel	E347 580
Zugfeder	E765 600
Kurzkupplung	E701 630
Puffer rund	E761 850
Puffer flach	E121 629
Führungsbock	E293 743

Gedeckter Güterwagen

Radsatz	E700 150
Radsatz	E700 580
Kurzkupplung	E701 630
Kupplungsdeichsel kurz	E372 680
Schaltschieberfeder	7 194
Puffer	E761 690
Schwellenstapel klein	E330 905
Schwellenstapel klein	E330 906
Stäbe u. Blockmagnet	E330 907

Hinweis: Einige Teile werden nur ohne oder mit anderer Farbgebung angeboten. Teile, die hier nicht aufgeführt sind, können nur im Rahmen einer Reparatur im Märklin-Reparatur-Service repariert werden.

Allgemeiner Hinweis zur Vermeidung elektromagnetischer Störungen:

Um den bestimmungsgemäßen Betrieb zu gewährleisten, ist ein permanenter, einwandfreier Rad-Schiene-Kontakt der Fahrzeuge erforderlich. Führen Sie keine Veränderungen an stromführenden Teilen durch.

Note: Several parts are offered unpainted or in another color. Parts that are not listed here can only be repaired by the Märklin repair service department.

General Note to Avoid Electromagnetic Interference:

A permanent, flawless wheel-rail contact is required in order to guarantee operation for which a model is designed. Do not make any changes to current-conducting parts.

Remarque : Certains éléments sont proposés uniquement sans livrée ou dans une livrée différente. Les pièces ne figurant pas dans cette liste peuvent être réparées uniquement par le service de réparation Märklin.

Indication d'ordre général pour éviter les interférences électromagnétiques:

La garantie de l'exploitation normale nécessite un contact roue-rail permanent et irréprochable.

Ne procédez à aucune modification sur des éléments conducteurs de courant.

Opmerking: enkele delen worden alleen kleurloos of in een andere kleur aangeboden. Delen die niet in de in de lijst voorkomen, kunnen alleen via een reparatie in het Märklin-service-centrum hersteld/vervangen worden.

Algemene aanwijzing voor het vermijden van elektromagnetische storingen:

Om een betrouwbaar bedrijf te garanderen is een permanent, vlekkeloos wielas - rail contact van het voertuig noodzakelijk. Voer geen wijzigingen uit aan de stroomvoerende delen.

Nota: algunas piezas están disponibles sólo sin o con otro color. Las piezas que no figuran aquí pueden repararse únicamente en el marco de una reparación en el servicio de reparación de Märklin.

Consejo general para evitar las interferencias electromagnéticas:

Para garantizar un funcionamiento según las previsiones se requiere un contacto rueda-carril de los vehículos permanente sin anomalías. No realice ninguna modificación en piezas conductoras de la corriente.

Avvertenza: Alcuni elementi vengono proposti solo senza o con differente colorazione. I pezzi che non sono qui specificati possono venire riparati soltanto nel quadro di una riparazione presso il Servizio Riparazioni Märklin.

Avvertenza generale per la prevenzione di disturbi elettromagnetici:

Per garantire l'esercizio conforme alla destinazione è necessario un contatto ruota-rotaila dei rotabili permanente, esente da interruzioni. Non eseguite alcuna modificazione ai componenti conduttori di corrente.

Observera: Vissa delar finns endast att tillgå från Märklin olackerade eller i en annan färgsättning. Delar som ej finns upptagna här kan endast erhållas i samband med att reparationen genomförs på Märklins egen verkstad: Märklin Reparatur-Service.

Allmän information för undvikande av elmagnetiska störningar:

För att kunna garantera en problemfri trafik fordras först och främst fullgod kontakt mellan rälsen och fordonens/vagnarna hjul. Förändra inte lokens och vagnarnas strömledande delar och detaljer.

Bemærk: Nogle dele udbydes kun med eller uden anden farvesammensætning. Dele, der ikke er anført her, kan kun repareres i forbindelse med en reparation i Märklins reparationservice.

Generel vejledning til forhindring af elektromagnetiske forstyrrelser:

For at sikre normal drift, er permanent, problemfri hjul-skinne-kontakt på køretøjerne påkrævet. Undgå at foretage ændringer på strømførende dele.

Gebr. Märklin & Cie. GmbH
Stuttgarter Str. 55 - 57
73033 Göppingen
Germany
www.maerklin.com



www.maerklin.com/en/imprint.html

295715/1121/Sc3Ef
Änderungen vorbehalten
© Gebr. Märklin & Cie. GmbH